

3 Phase / 1 Phase, Heavy Duty Industrial Induction Motors

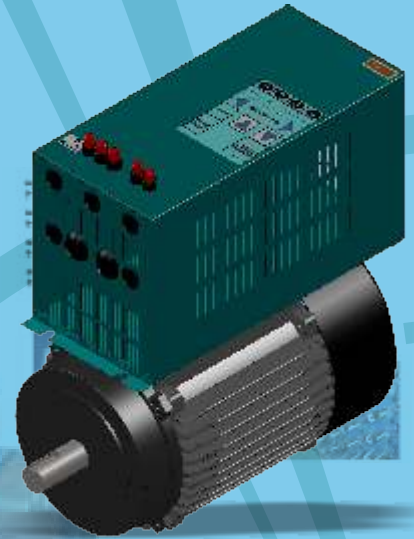

Fractional HP Motors



Motors with VFD



Standard Motors



Loom/Stirrer Motors



Motors with Control Box



Special Mounting, Dual Speed Motors



Torque Motors

SALIENT FEATURES:
Energy Efficient IE2 | B3,B5 & B14 Flanges | Custom made Flanges & Mountings |
CE Marking | F-Class Insulation, B-class Temp Raise |
Class H Optional | Conforms to IS325 & IS12615

Customised Induction Motors - On-time Delivery & Economical Too!

Product of Proven Performance

Motor RPM	Frame / Motor power in kW																	
	RM56	RM63				RM71		RM80		RM90		RM100		RM112		RM132		
3000	0.08	0.10	0.18	0.25	0.30	0.37	0.54	0.75	1.10	1.50	2.00	2.25	3.00	3.70	4.00	5.50	7.50	10.00
1500	0.06	0.18	0.18	----	----	0.37	----	0.75	----	1.10	----	2.25	----	----	----	----	----	----
1000	----	----	----	----	----	0.25	----	----	----	----	----	----	----	----	----	----	----	----

Single Phase 230V/ 50 Hz Motors

3000	0.08	0.1	0.18	0.25		0.37	0.54	0.75										
1500	0.05		0.18			0.37		0.75				1.5						
1000																		

Dual Speed Motors

Motor Rated RPM	RM90	RM100	RM112	Rm132
3000 / 1500	1.6 / 1.2	2.4 / 2.0	4.0 / 1.2	7.5 / 5.5
1500 / 750	1.5 / 0.55	3.3 / 0.75		4.3 / 2.9

Torque Motors

Motor Rated RPM	Motor Frame/ Torque in Nm	
	RM63	RM71
1500	4	
1000	6	10

3 - PHASE INDUCTION MOTOR RM (FOOT MOUNTED) SERIES

FRAME RM	A	B	C	H	K	L	AA	AB	AD	BA	AC	BB	HA	HD	D	E	F	GA	GD	Wt. Kg.
56	90	71	36	56	5.8	194	28	102	112	26	54	90	6	139	9	20	3	10.2		2.5
63	100	80	40	63	7.0	215	33	125	127	31	125	95	10	155	11	23	4	12.5		5.0
71S	112	90	45	71	7.0	235	37	141	140	35	145	120	10	181	14	30	5	16		8.5
80M/L	125	100	50	80	10	290	30	155	156	30	160	125	10	158	19	40	6	21.5		12.5
90L	140	100	56	90	10.0	315	36	170	179	36	175	125	10	180	24	50	8	27.0		29.0
100M/L	160	140	63	100	12	395	40	200	155	40	200	170	10	230	28	60	8	31		35.0
112M	190	140	70	112	12	425	40	230	225	40	165	180	10	240	28	60	8	31		38.0
132	216	140	89	132	12	550	40	256	185	40	260	178	12	262	38k6	80	10h9	41		63.0

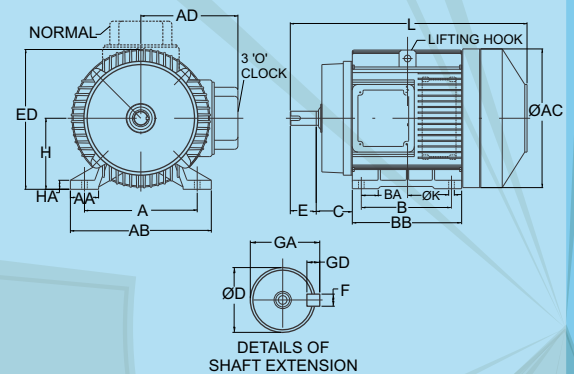

3 - PHASE INDUCTION MOTOR RMB SERIES

B (B5) TYPE FLANGE MOTORS DIMENSIONS - RMB SERIES:

FRAME RMB	M	N (j6)	P	S	T	L MAX	AD MAX	AC MAX	LA	LB	D (j6)	E	F (h9)	GD	GA	LD	Wt. Kg.
56	75	55	100	7	3.0	160	102	90	8	140	9	20	4	4	10.2		2.5
63	115	95	140	10	3.0	173	90	115	9	175	11	23	4	4	12.5		3.5
71S	130	110	160	10	3.5	230	90	145	9	230	14	30	5	5	16		9.0
80M/L	165	130	200	12	3.5	290	130	160	10	265	19	40	6	6	21.5		9.5
90L	165	130	200	12	3.5	350	130	170	10	280	24	50	8	7	27.0		30.0
100M/L	215	180	250	15	4	295	150	200	11	355	28	60	8	7	31		35.0
112M	215	180	250	15	4	425	150	200	11	355	28	60	8	7	31		40.0

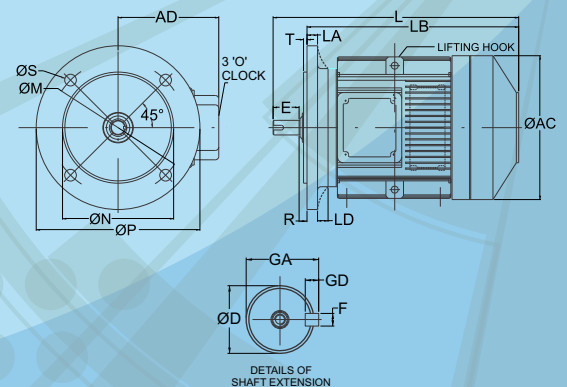

3 - PHASE INDUCTION MOTOR RMC SERIES

C (B14) TYPE FLANGE MOTORS DIMENSIONS – RMC SERIES:

FRAME RMC	M	N (j6)	P	S	T	L MAX	AD MAX	AC MAX	LB	D (j6)	E (h9)	F	GD	GA	Wt. Kg.
56	55	40	90	M5	2.5	160	90	105	150	9	20	4	4	10.2	2.8
63	75	60	100	M5	2.5	173	90	115	175	11	23	4	4	12.5	4.0
71S	85	70	108	M6	2.5	230	143	145	230	14	30	5	5	16	8.5
80M/L	100	80	125	M6	3.0	290	130	170	260	19	40	6	6	21.5	12.0
90L	115	95	145	M8	3.0	350	130	170	275	24	50	8	7	27.0	30.0
100M/L	130	110	165	M8	3.5	295	145	200	350	28	60	8	7	31	35.0
112M	130	110	175	M8	3.5	425	165	235	350	28	60	8	7	31	40.0
132	165	130j6	220	M12	3.5	550	190	260	470	38k6	80	10h9	8	41	63.0

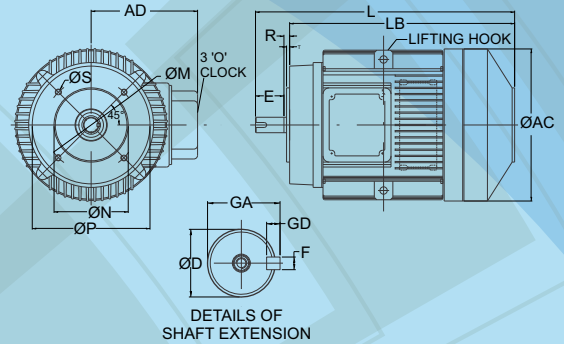

MOTORS WITH GEAR BOX

Gear Box RGB65

Gear Ratio - 1:72

Power (W)	40	80	120	180
RPM	32	32	32	32
	16	16		16

Silent Features:

All ball bearing | Good Finish | Smooth running | Grease filled for life

3 phase / 1 Phase Motors with Gear Box RGB65

Power (W)	40	80	120	180
RPM		0-48		

Motors With Gear Box RGB65 & Variable Frequency Drive (VFD): For continuous speed variation

Power (W)	100 W Max
RPM	0-48

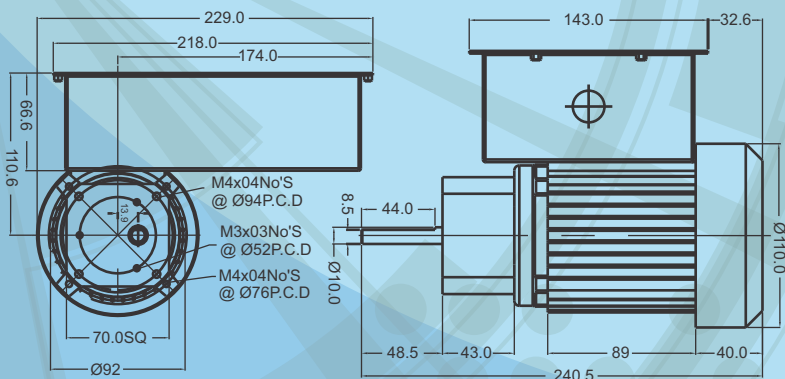
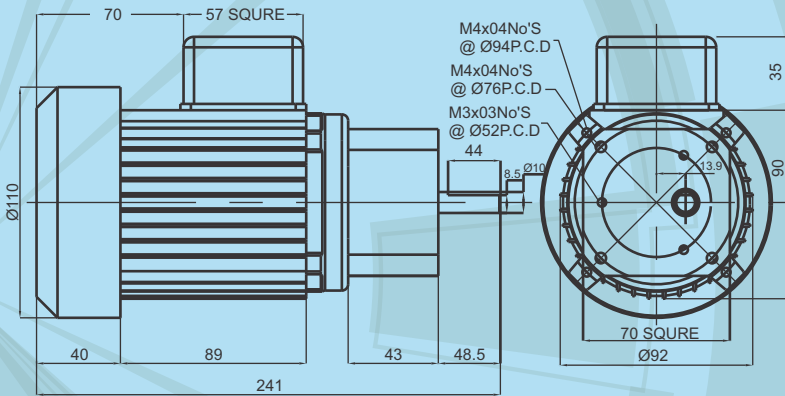
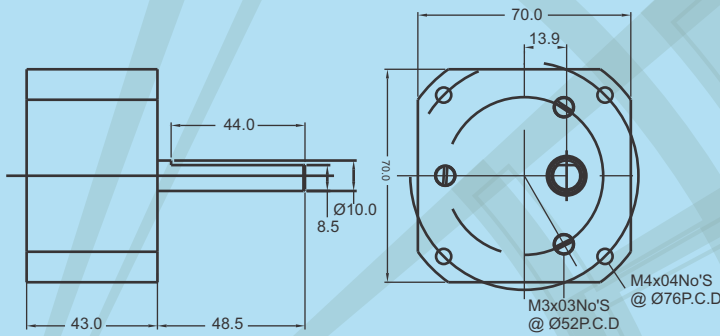

BLDC Motor with Controller & Gear Box RGB65: 24V DC- Battery or Solar operated
Refer above diagram and table for details

Coolant Pumps



Oil Skimmers



Dealer Network

▲ **Factory / Head Office**

● **Dealers / Representative**



REFUELING PUMP WITH ACCESSORIES

Manufacturer:

Rajamane Industries Pvt Ltd.,
 Whitefield Road, Mahadevapura Post,
 Bangalore 560 048 India
 Ph: +91-80-43659000, Fax: +91-80-28524320
 Email : motors@rajamane.com
 web: www.rajamane.com

Dealer:

